

1910 2010 100



# BLITZDUCTOR® XTU

## Universal lightning current and surge arrester with actiVsense.



## Universal lightning current / surge arrester

- With actiVsense technology
  - Automatically detects the operating voltage of the wanted signal from 0 to 180 V
  - Optimally adjusts the voltage protection level to the operating voltage currently applied
  - Low voltage protection level, also suited for the protection of terminal equipment
- Eases your processes
  - Reduction of the variety of types
  - Only one type of SPD for different signal lines
  - Easy planning and storage
  - Can be easily retrofitted

BLITZDUCTOR XTU combined lightning current and surge arresters for the protection of information and automation systems stand out due to their new, revolutionary technology: The nominal voltage is not specified thus the arrester can be used for any voltage in the range from 0 to 180 V d.c. Its innovative technology allows the arrester to automatically detect the signal voltage of the wanted signal and to adjust its protection performance to this voltage. Moreover, it continuously adjusts its voltage protection level to the operating voltage currently applied and is thus ideally suited for all applications where changing voltages occur.

In case of interference, BLITZDUCTOR XTU arresters always have an adjusted, minimal residual voltage for every signal voltage thus providing maximum protection for the devices and systems connected to them.

BLITZDUCTOR XTU arresters also considerably reduce planning efforts and minimise storage requirements. Even if it is not known at the planning stage which voltages are used for signal transmission, BLITZDUCTOR XTU arresters now allow to specify a concrete protective device even at the planning stage thus facilitating procurement and storage at the execution stage of the project.

BLITZDUCTOR XTU arresters are also ideally suited to be retrofitted into existing systems or to replace existing arresters as it is frequently not entirely clear which types of nominal voltage are to be used. This does not matter if BLITZDUCTOR XTU arresters are used.

## PLUGGABLE SPDS FOR DIN RAIL MOUNTING



Example of use of BLITZDUCTOR XTU.



Completely mounted BLITZDUCTOR XTU. Two-part design with base part and SPD module. Particularly space-saving, for DIN rail mounting.

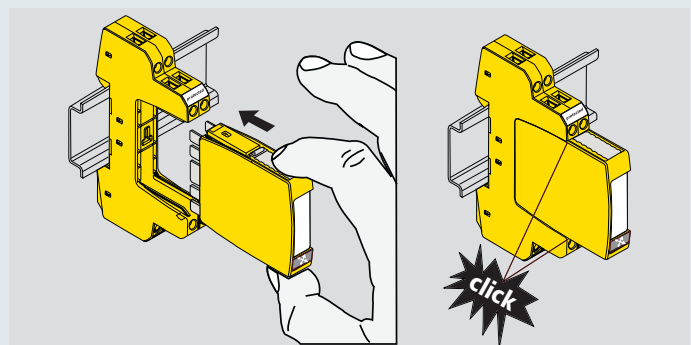

The function-optimised design of the arrester allows both to safely plug the arrester module into the base part and to remove it easily. The module is secured in the base part by snapping it in (audible click). When pressing the grey buttons, the module can be removed with little effort. This is ensured by the laminated contacts in the base part and the release spring of the module. A mechanical reverse voltage protection ensures that the module is installed in the correct position.



Testing of an SPD module via RFID technology (LifeCheck)

BLITZDUCTOR XTU arresters are pluggable, multipole and universal DIN rail mounted lightning current and surge arresters for the protection of measuring and control circuits, bus systems and telecommunication systems in which high levels of availability are essential. For effective protection of terminal equipment against lightning effects and surges, BLITZDUCTOR XTU arresters combine the permanently high impulse current discharge capacity of a lightning current arrester with the low voltage protection level of a surge arrester which is optimally adjusted to the operating voltage currently applied.

LifeCheck allows easy and fast testing of SPDs without removing the module from the system circuit. Integrated into the SPD modules, LifeCheck permanently monitors the proper condition of the SPD and acts like an early warning system, detecting electrical or thermal overload of the protection components. The LifeCheck status can be read out within a matter of seconds via contactless RFID technology by means of the portable DEHNrecord LC reader and shows the date of the last test of the SPD module.

Stationary installed, a condition monitoring system allows condition-based maintenance of 10 BXT arresters (for more detailed information, please refer to page 6).

The module locking mechanism ensures safe operation, thus the arrester provides protection against vibration effects and shock loads up to a 30-fold acceleration of gravity. The function-optimised design of the arrester ensures both fast and easy replacement of the arrester module which houses all relevant protection elements.

A wide range of accessories makes the BLITZDUCTOR XTU arrester particularly user-friendly. Elements for labelling, earthing of unused lines or easy testing of lines complete the product range.

- Combined lightning current and surge arrester
  - Capable of carrying lightning currents up to 10 kA (10/350  $\mu$ s)
  - Low voltage protection level, also suited for the protection of terminal equipment
  - For use in conformity with the lightning protection zones concept at the boundaries from  $0_A - 2$  and higher
- SPD consists of a protection module and base part
  - Easy replacement of protection modules
  - Make-before-break switch contact in the base part allows removal and insertion without interruption
- With integrated LifeCheck monitoring function
  - SPDs can be tested without downtime
  - Even detects previously damaged arresters

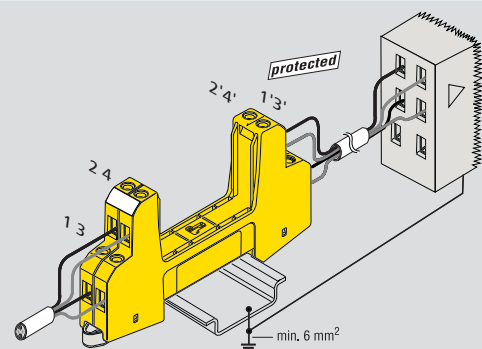

Up to four lines can be connected on two levels. For DIN rail mounting purposes, lines of a pair belonging to each other are connected on top of one another.

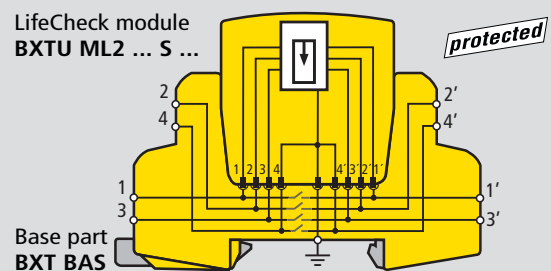

If the line shield cannot be directly earthed on both sides for technical reasons, one-sided indirect shield earthing might be advisable. This can be performed by using arrester modules of type BXTU ML2 ... S. The terminal 3, 3' is connected to a gas discharge tube which is capable of carrying lightning currents and prevents compensating currents. Transient impulse currents on the shield are discharged via indirect shield earthing.

**BXTU ML4 BD 0-180 /  
BXTU ML2 BD S 0-180**

**PLUGGABLE SPDS FOR DIN RAIL MOUNTING**

**NEW**

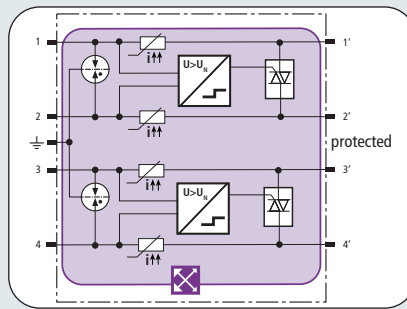

Basic circuit diagram BXTU ML4 BD 0-180

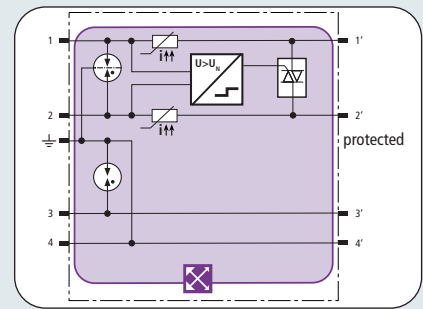

Basic circuit diagram BXTU ML2 BD S 0-180

- Universal voltage type with actiVsense technology
- For installation in compliance with the lightning protection zones concept at all boundaries from 0<sub>A</sub> – 2 or higher
- With integrated LifeCheck monitoring function

Space-saving combined SPD module with actiVsense and LifeCheck technology for protecting lines of balanced interfaces which are galvanically isolated.

**BXTU ML4 BD 0-180:** for even with different operating voltages isolated pairs

**BXTU ML2 BD S 0-180:** for one pair, with direct or indirect shield earthing

Automatically detects the operating voltage of the wanted signal and optimally adjusts the voltage protection level to the operating voltage currently applied.

**BXTU ML4 BD 0-180**

**BXTU ML2 BD S 0-180**

	<b>TYPE 1 P1</b>	<b>TYPE 1 P1</b>
SPD class	LifeCheck	LifeCheck
SPD monitoring system	LifeCheck	LifeCheck
Operating voltage U <sub>N</sub>	0 - 180 V	0 - 180 V
Frequency of the operating voltage f <sub>UN</sub>	≤ 400 Hz	≤ 400 Hz
Max. continuous operating d.c. voltage U <sub>C</sub>	180 V	180 V
Max. continuous operating a.c. voltage U <sub>C</sub>	127 V	127 V
Permissible superimposed signal voltage U <sub>Signal</sub>	≤ +/- 5 V	≤ +/- 5 V
Cut-off frequency line-line (U <sub>Signal</sub> , balanced 100 ohms) f <sub>G</sub>	25 MHz	25 MHz
Nominal current at 80° C I <sub>L</sub>	100 mA	100 mA
D1 Total lightning impulse current (10/350 μs) I <sub>imp</sub>	10 kA	9 kA
D1 Lightning impulse current (10/350 μs) per line I <sub>imp</sub>	2.5 kA	2.5 kA
C2 Total nominal discharge current (8/20 μs) I <sub>n</sub>	20 kA	20 kA
C2 Nominal discharge current (8/20 μs) per line I <sub>n</sub>	10 kA	10 kA
Voltage protection level line-line for I <sub>n</sub> C2 U <sub>p</sub>	see diagram, line C2	see diagram, line C2
Voltage protection level line-line at 1 kV/μs C3 U <sub>p</sub>	see diagram, line C3	see diagram, line C3
Voltage protection level line-line for I <sub>imp</sub> D1 U <sub>p</sub>	≤ U <sub>N</sub> + 53 V	≤ U <sub>N</sub> + 53 V
Voltage protection level line-PG for C2/C3/D1	≤ 550 V	≤ 550 V
Series impedance per line R	≤ 10 ohms; typically 7.5 ohms	≤ 10 ohms; typically 7.5 ohms
Capacitance line-line C	≤ 200 pF	≤ 200 pF
Capacitance line-PG C	≤ 16 pF	≤ 25 pF
Operating temperature range	-40°C...+80°C	-40°C...+80°C
Degree of protection (SPD plugged-in)	IP 20	IP 20
Pluggable into	BXT BAS base part	BXT BAS base part
Earthing via	BXT BAS base part	BXT BAS base part
Enclosure material	polyamide PA 6.6	polyamide PA 6.6
Colour	yellow	yellow
Test standards	EN 61643-21	EN 61643-21
Approvals, Certifications	GOST	GOST

Ordering information		
Type	BXTU ML4 BD 0-180	BXTU ML2 BD S 0-180
Part No.	920 349	920 249
Packing unit	1 pc(s).	1 pc(s).

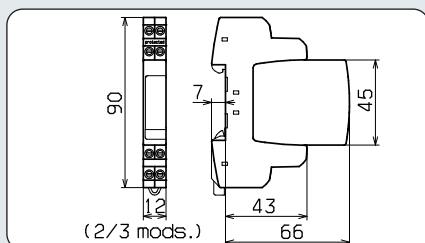

- Dimension drawing of BLITZDUCTOR XTU base part with plugged-in arrester module
- Width: 2/3 modules (12 mm), suitable for DIN rail mounting in distribution boards

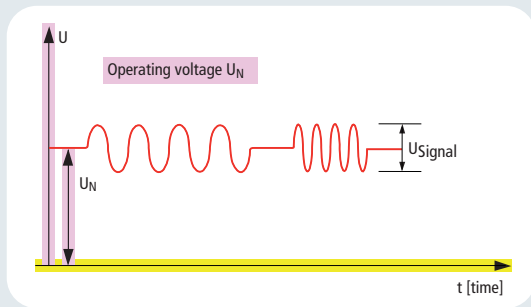

Operating voltage  $U_N$  and superimposed signal voltage  $U_{Signal}$

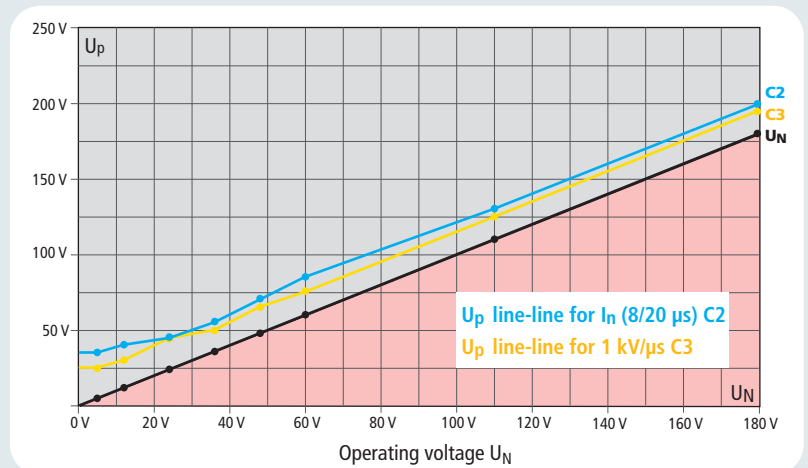

Voltage protection level  $U_p$  as a function of the operating voltage  $U_N$

BLITZDUCTOR® XT Base Part

BXT BAS

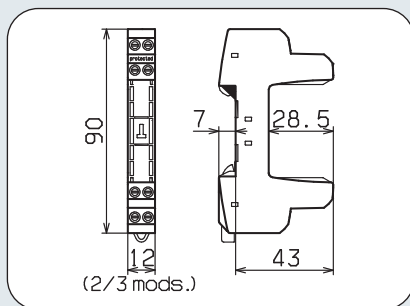

Dimension drawing BXT BAS

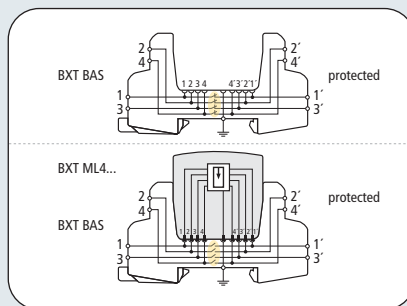

Basic circuit diagram with and without plug-in module



- Four-pole version for universal use with all types of SPD modules
- The modules can be plugged in and removed without signal interruption
- Universal design without protection elements

The BLITZDUCTOR XT base part is a very space-saving, four-pole, universal feed-through terminal for the insertion of SPD modules without signal interruption. The snap-in mechanism at the supporting foot of the base part allows the device to be safely earthed via the DIN rail. As no components of the protective circuit are situated in the base part, maintenance operation is only required for the protection modules.

BXT BAS	
Operating temperature range	-40°C...+80°C
Degree of protection	IP 20
For mounting on	35 mm DIN rail acc. to EN 60715
Connection type input / output	screw / screw
Cross-sectional area, solid	0.08 - 4 mm <sup>2</sup>
Cross-sectional area, flexible	0.08 - 2.5 mm <sup>2</sup>
Tightening torque (terminals)	0.4 Nm
Earthing via	35 mm DIN rail acc. to EN 60715
Enclosure material	polyamide PA 6.6
Colour	yellow
Ex certifications *)	ATEX: KEMA 09ATEX0114 X: II 3 G Ex nA II T4 IECEx KEM 09.0053X: Ex nA II T4 Gc
Approvals, Certifications	CSA, VdS, UL, GOST
Ordering information	
Type	BXT BAS
Part No.	920 300
Packing unit	1 pc(s).

\*) In combination with certified module

- Maximum protection and availability of systems by means of permanent condition monitoring of LifeCheck-equipped SPDs
- The early detection system already detects arrester overload and warns of imminent failure of the arrester
  - Visual indication of faulty or previously damaged SPDs
  - Compact dimensions and minimum wiring
  - Monitoring of up to 10 SPDs (40 signal lines)
  - Remote signalling contact
  - Remote signalling also via RS 485 interface and PC software



Example of use of the DEHNrecord condition monitoring system.

## Condition Monitoring:

The DRC MCM XT condition monitoring system is a compact DIN rail mounted device for monitoring the condition of up to 10 pre-programmed BXT arresters with integrated LifeCheck monitoring circuit.

Integrated into the SPD modules, LifeCheck permanently monitors the proper condition of the SPD and acts like an early warning system, detecting imminent electrical or thermal overload of the protection components. The LifeCheck status can be read out within a matter of seconds via contactless RFID technology by means of the portable DEHNrecord LC device and also shows the date of the last test of the SPD module. Stationary installed, the condition monitoring system supports condition-based maintenance of 10 BXT.

The unit acts like an early warning system, generating a fault message even in case of imminent arrester overload, indicates it by means of the integrated three-colour LED and transmits it to one of the two integrated remote signalling contacts. Failure of the monitoring unit, e.g. due to a voltage breakdown, is also indicated via the remote signalling contact. The Show function integrated into the DRC MCM system allows to detect previously damaged SPDs in the monitoring group.

If several condition monitoring systems are used in one switchgear cabinet, these systems are connected via the integrated RS 485 interfaces to synchronise the monitoring cycles. Up to 15 DRC MCM systems can be connected to the RS 485 bus. Thus, up to 150 BLITZDUCTORs or 300 pairs can be monitored simultaneously with minimum wiring effort.

## The "Status Display and Service Console" PC software

is an optional user software for the DRC MCM XT condition monitoring system which indicates the status of the SPDs and addresses LifeCheck-equipped BLITZDUCTOR modules.

The software can be installed on a standard PC using an RS485/USB interface converter of type "USB-NANO 485" which is available as accessory.

The software can be downloaded free of charge from [www.dehn.de/download/](http://www.dehn.de/download/) or is available as CD for a nominal fee.

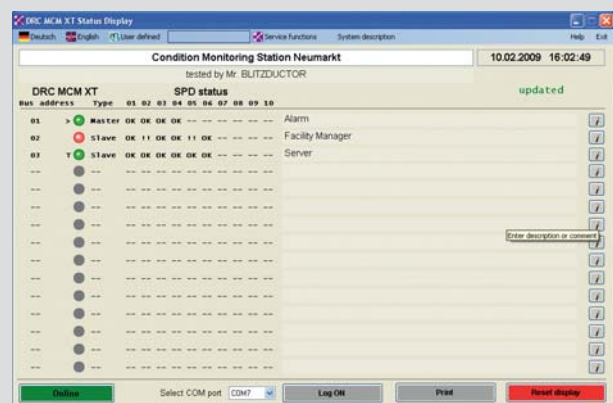

Graphical status indication of DRC MCM XT monitoring devices and of all programmed protection modules assigned to them.

The Service functions allow to switch to the "Service Console" function complex. The protection modules can be easily addressed, tested and reset due to the user-friendly user interface.

### LifeCheck® Condition Monitoring System

#### DRC MCM XT

DIN rail mounted device with integrated LifeCheck sensor for monitoring the condition of max. 10 LifeCheck-equipped "BLITZDUCTOR XT" devices. Visual three-coloured SPD operating state indication combined with remote signalling function (break or make contact). The free "Status Display and Service Console" software can be optionally used via an RS 485 interface converter.



Type	PU pc(s).	Part No.
DRC MCM XT	1	910 695

#### Accessory for LifeCheck® Condition Monitoring System

##### USB interface converter of type USB NANO 485

USB NANO 485 converts signals between USB and RS-485. The interface converter is specifically designed for 2-wire RS-485 buses. LEDs indicate operation (yellow), Rx (green) and Tx (red).

USB NANO 485 is ideally suited for use with notebooks due to its small size. Stationary use is also possible.



Type	PU pc(s).	Part No.
USB NANO 485	1	910 486

### LifeCheck® SPD Test Device

#### DRC LC M3+

Portable device with LifeCheck sensor for flexible use. For fast and easy testing of LifeCheck-equipped arresters. Visual and acoustic indication. With additional USB connection and database software for PC-aided management of test objects and documentation of the test results. DRC LC M3+ features a new snap-on LifeCheck sensor, allowing to test the SPD without holding the sensor. The handheld device allows parameterisation of SPDs for condition monitoring.

Type	DRC LC M3+
Testing of	BLITZDUCTOR XT ML BLITZDUCTOR XT ML EX for use in non-hazardous atmospheres only!

Measured value indication: beep and LCD  
Testing period: typically 3 to 10 sec.  
Delivery includes: handheld device, LifeCheck sensor BXT, charging device, USB cable, test module for reference, software CD, storage case



Type	PU pc(s).	Part No.
DRC LC M3+	1	910 653

#### Accessory for LifeCheck® Test Device

##### LifeCheck-Sensor für DRC BXT

LifeCheck snap-on sensor and test module for use as spare part / extension for portable LifeCheck test devices. With snap-on feature!



Type	Testing of	PU pc(s).	Part No.
LCS DRC BXT	BLITZDUCTOR XT ML	1	910 652

##### LifeCheck-Sensor für DRC BCT

LifeCheck sensor and test module for use as spare part / extension for portable LifeCheck test devices.



Type	Testing of	PU pc(s).	Part No.
LCS DRC BCT	BLITZDUCTOR CT MLC	1	910 654

#### Accessory for BLITZDUCTOR® XT Base Part

##### Earthing module

For direct earthing of lines connected to the BLITZDUCTOR XT base part.



Type	PU pc(s).	Part No.
BXT M4 E	1	920 308

##### Test / Disconnection Module

Module for testing lines, to be plugged into the BLITZDUCTOR XT base part.



Type	PU pc(s).	Part No.
BXT M4 T	1	920 309

##### Marking System BA1-BA15

2 x 165 adhesive labels for labelling DRC MCM XT monitoring devices with their bus address (BA1 to BA15) and BXT base parts or modules with consecutive numbers (1.1-1.10 to 15.1-15.10)



Type	PU pc(s).	Part No.
BS BA1 BA15 BXT	1	920 398

##### EMC Spring Terminals

Two spring terminals for permanent low-impedance shield contact with the protected and unprotected side of a BXT device. With integrated terminal coding for direct or indirect shield earthing, cable ties and insulating strips included.



Type	PU pc(s).	Part No.
SAK BXT LR	1	920 395

##### Partition

For DRC MCM XT

Certain installation instructions have to be observed when using Blitzductor XT Ex (i) surge protective devices in intrinsically safe circuits.

In accordance with EN 60079-11;2007 a minimum distance (thread measure) of  $\geq 50$  mm has to be maintained between intrinsically and non-intrinsically safe circuits (connecting parts, e.g. terminals)!

When using the Ex i partition of type TW DRC MCM EX, this distance is also maintained if the surge protective devices are arranged directly next to one other.



Type	PU pc(s).	Part No.
TW DRC MCM EX	1	910 697



**Lightning Protection  
Surge Protection  
Safety Equipment**

DEHN + SÖHNE  
GmbH + Co.KG.  
Hans-Dehn-Str. 1  
Postfach 1640  
92306 Neumarkt  
Germany

Tel. +49 9181 906-0  
Fax +49 9181 906-100  
[www.dehn.de](http://www.dehn.de)  
[info@dehn.de](mailto:info@dehn.de)

More information material  
and services e.g.

- Surge Protection  
main catalogue
- Lightning Protection  
main catalogue
- Appointment with  
our sales engineer

please visit our homepage:  
[www.dehn.de](http://www.dehn.de) "Service" section